



CHS Controls AB
Tel +46 42 38 61 00, Fax +46 42 38 61 29
chs@chscontrols.se www.chscontrols.se



CHEKVOLT® (R-3MT-VI)

INSTALLATION GUIDE & OPERATING INSTRUCTIONS

Non-Hazardous Locations		
Indoor	Indoor/Outdoor	Ingress Protection
UL Type 12, 13	UL Type 4, 4X	IP2X, IP66, IP69 per IEC 60529
Approvals		
CSA C22.2 No. 94.2/ UL 50E	UL 61010-1 3rd Ed. with AMD 1	CAT III 1000V
CAT IV 600V	CE	UL/CSA 61010-2-030 2nd Ed.
EN 61010-2-030 2nd Ed.		

For technical questions call 1-800-280-9517 and select Option 3 for Technical Support when prompted

Grace Technologies, Inc. • 1515 E Kimberly Road • Davenport, Iowa 52807
Phone: 1-800-280-9517 • **Fax:** (563)386-9639 • www.pesd.com

**CHS Controls AB**

Tel +46 42 38 61 00, Fax +46 42 38 61 29

chs@chscontrols.se www.chscontrols.se



ChekVolt® is a combination device used to verify the voltage presence using visual indication and absence through a metered test.

SPECIFICATIONS

AC Operational Voltage Range	Test Point: AC Single 1 ~ or 3-Phase 3 ~: 0 - 1000V ~ @ 50/60/400Hz Voltage Indicator: AC Single 1 ~ or 3-Phase 3 ~: 20-1000V, 50/60/400 Hz
DC Voltage or Stored Energy Range	Test Point: 0 - 1000V --- any (2) wires Voltage Indicator: 20 - 1000V ---, (Voltages Line-to-Line or Line-to-Ground)
Maximum Voltage	1000V 3 ~ or 1000V ---
Maximum Power Consumption	Test Point: 3 Watts @ 1000V (approx.) with fault load of any (2) corresponding test points shorted indefinitely Voltage Indicator: 2.1 Watts
Temperatures	Operate: -20°C to +55°C Storage: -45°C to +85°C
Failure Current	Maximum single component failure fault current at 1000V ~ or 1000V --- Test Point: 3.2mA with a momentary short between any (2) test points Voltage Indicator: 3.7mA with any (1) line input series power resistor shorted
Internal Resistance	Test Point: (2) 82K 3W 5% Tolerance series resistors encapsulated between each input wire and respective test point (164KΩ 6W equivalent between any two test points)
Output Accuracy	-3.2% of applied voltage with 10M Ω input impedance voltmeter connected to any (2) test points
Terminations	(4) Wires, 8 ft, 14 AWG, 90°C @ 1000V, UL-1452, PVC Insulated w/ Nylon Jacket
Voltage Category Ratings	CAT III @ 1000V ~ Max, Pollution Degree 3, CAT IV @ 600 V ~ Max, pollution Degree 3
Housing	UL Approved material, totally encapsulated including LEDs for environmental protection
Indicators:	(6) Red {L1, L2, L3} and (2) Yellow {GND}, Super Bright LEDs

Note: All above ratings are LINE-TO-LINE or LINE-TO-GND



**UL Type 4,
4X, 12, 13,
IP2X, IP66,
IP69**

WIRE IDENTIFICATION

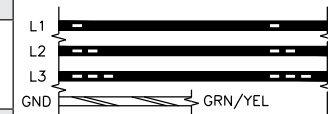

---	Direct Current
~	Alternating Current Single Phase or 3-Phase
⚠	Caution
⚡	Caution, possibility of electrical shock



⚠ BE SURE POWER IS SHUT OFF PRIOR TO INSTALLING THIS DEVICE.

⚠ CAUTION

- ALWAYS connect the GRN/YEL (GND) conductor to earth ground.
- Location of device and internal hardware/wiring MUST allow free operation of ON/OFF disconnect mean. For indoor use only.
- Means of anti-rotation is required (see knock-out for one or more tab locations).
- The O-ring material is FVMQ fluorosilicone. Please refer to a Chemical Compatibility chart for your application(s).
- Maximum single component failure fault current is 3.2mA @ 1000V \sim or 1000V --- with a momentary short between any (2) test points.
- Do not operate above 1000V \sim or 1000V --- @ 55°C ambient or >2000m altitude or >80% RH.
- If this product is used in a manner not herein prescribed, the protection provided may be impaired.

⚠ WARNING Use of an Overcurrent Protection Device or Fuse is "NOT RECOMMENDED" when installing these devices in safety applications for verifying both voltage presence and voltage absence condition. A blown fuse or a tripped circuit breaker connected in line with this device could potentially lead to a false negative indication of voltage which is otherwise present. This device has been tested as equivalent to overcurrent protection for the application of tap conductor requirements.



CHS Controls AB

Tel +46 42 38 61 00, Fax +46 42 38 61 29

chs@chscontrols.se www.chscontrols.se



INSTALLATION INSTRUCTIONS

1. Follow all Local, State, and National Electrical Codes when installing this equipment. Overcurrent protection is not recommended. If device leads are either extended beyond the supplied length or the device installation extends beyond the enclosure where the leads are terminated, overcurrent protection of the supply leads may be required by Local, State or National Electric Codes. The installation of overcurrent protection shall be in accordance with the requirements in the NEC (NFPA 70) or end product standard(s) when used in final installation.
2. Locate the unit in visual proximity to the control panel ON/OFF disconnect and within wiring distance to incoming Main Lines and Earth Ground. Mount the unit through a 30.5 mm knockout hole on the three-phase control panel to be monitored. To meet Type 12, 13, 4, or 4X sealing requirements, mount with supplied cap on a clean flat surface or inside a Type 4 or 4X housing.
(Fig. 1)
3. For Delta configured power, connect 1 bar, 2 bar & 3 bar black wires to L1, L2 & L3 respectively (Fig. 1) on the fused or disconnect side of the 3-Phase line voltage. The Green/Yellow stripe (Grn/Yel) wire MUST be connected to Earth Ground.
(Fig. 2)
4. With the R-3MT-VI installed, wired, and the enclosure closed, verify the power disconnect is OFF.
5. Using the proper test equipment: the voltmeter should be rated for Cat III/1000V and Cat IV/1000V. Test probes should be fully insulated with .080" DIA points to insert into test point jacks.
6. Follow all safety and lock-out/Tag-out (LOTO) procedures. Set voltmeter to ACV, verify zero voltage between (6) test point combinations {L1-L2, L1-L3, L2-L3, L1-GND, L2-GND, L3-GND}, Switch meter to DCV. Repeat all (6) measurements.
7. STORED ENERGY is present whenever DCV readings are observed. The energy must be removed or discharged before the enclosure is to be opened or electrician work is to be performed.
8. Remove any unsafe load conditions and notify personnel power is about to be restored. Turn power ON.
9. Repeat step 6 measurements but now verify proper operating voltage conditions appear on the Test Point combinations.

Note: For greater accuracy, multiply voltmeter reading by a factor of 1.03 to determine actual line voltage.)



CHS Controls AB

Tel +46 42 38 61 00, Fax +46 42 38 61 29

chs@chscontrols.se www.chscontrols.se



Indicator Flash Rates (L1, L2, L3, GND)

3 ~ Line-to-Line (VAC)	<15	20	30	120	240	480	600	750	1000
Flashes/Sec (typical)	0	1	1.5	3	3.9	4.5	4.6	4.8	4.9
1 ~ Line-to-Line (VAC)	<18	20	30	120	240	480	600	750	1000
Flashes/Sec (Typical)	0	0.8	1.2	2.6	3.6	4.2	4.6	4.8	5
--- or Stored Energy (DC)	<16	20	30	48	110	300	600	1000	
Flashes/Sec (Typical)	0	1.3	1.8	2.3	3.2	4.5	4.8	4.9	

Equipment needed: Digital voltmeter with 1000V AC or 1000V DC rated input minimum, 10M Ω input impedance and CAT III & IV. A pair of insulated test probes with .080" DIA. points.

Directions: Before and after each test, determine the voltmeter is operating satisfactorily through verification of known AC & DC voltage sources. With the meter switched to VAC and test leads in ACV meter jacks, a qualified person can insert probe points into any two of the (4) terminal posts {L1, L2, L3, GND}.

1. To validate normal powered conditions, AC voltage is observed for all six (6) post pair combination circuits {L1-L2, L1-L3, L2-L3, L1-GND, L2-GND, L3-GND}.
2. To check for zero electrical energy during shut off, verify sources of feedback or stored energy are first neutralized. With the meter and leads setup for VAC measurement, verify the (6) post pair combination circuits above are de-energized. Change voltmeter and test leads for VDC measurement. Again verify the (6) post pair combination circuits are also de-energized for VDC (stored energy).
3. Ensure your facility personnel are properly trained with the use and limitations of these devices and properly update the "Point of Connections" on your installation drawings.

WARNING

BEFORE OPENING A PANEL, TURN POWER OFF! SAFETY PROCEDURES STILL APPLY!

Before working on an electrical conductor, verify zero electrical energy with proper voltage testing instrument and the proper procedure as per NFPA 70E 120.1(5), 120.2 (F)(2)(f)(1-6), OSHA 1910.333(b)(2)(iv)(B)."

AVANT D'OUVRIR UN PANNEAU ÉLECTRIQUE, COUPER L'ALIMENTATION! LES PROCÉDURES DE SÉCURITÉ S'APPLIQUENT TOUJOURS! Avant d'effectuer des travaux sur un conducteur électrique, vérifiez que le courant est coupé à l'aide d'un instrument de mesure de tension approprié en suivant la procédure adéquate, selon les normes de la NFPA (National Fire Protection Association) 70E 120.1(5), 120.2 (F)(2)(f)(1-6), de l'OSHA (Occupational Safety and Health Administration) 1910.333(b)(2)(iv)(B).

MAINTENANCE

With power removed, free dust and particles from the front of the label and dust cap with compressed air. Open the dust cap by unscrewing the cap screw and free the dust and particles on the inside of the cap and jack sockets with compressed air. Maintain a clean label by gently wiping with a clean damp cloth while power is removed. Cleaning while powered is not recommended.



CHS Controls AB

Tel +46 42 38 61 00, Fax +46 42 38 61 29

chs@chscontrols.se www.chscontrols.se



MEASUREMENT CATEGORY

The categories take into account the total continuous energy available at the given point of circuit, and the occurrence of impulse voltages. The energy can be limited by circuit breakers or fuses, and the impulse voltages by the nominal level of voltage. Maximum rated voltage of this device is 1000V AC or DC.

CAT III is for circuits which can be connected to the mains installation of a building. Energy is limited by circuit breakers to less than 110 000VA with the current not exceeding 11 000A.

CAT IV includes circuits which are connected directly to the source of power for a given building. There are very high levels of available energy (e.g. limited only by the power transformer) and arc flash can occur.

California Proposition 65

 **WARNING:** Cancer and Reproductive Harm



CHS Controls AB
 Tel +46 42 38 61 00, Fax +46 42 38 61 29
 chs@chscontrols.se www.chscontrols.se



ChekVolt® with Cap
 (R-3MT-VI & R-3MT-CAP)

Included in R-3MT-VI-KIT:

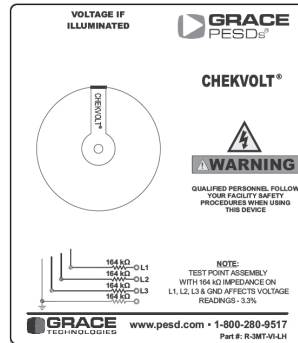

Horizontal Label*
 (R-3MT-VI-LH)

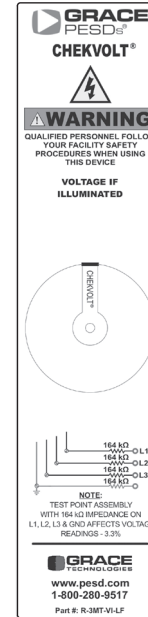

Flange Label*
 (R-3MT-VI-LF)

**Both the Horizontal and Flange labels are included in your kit. Use the appropriate label per your installation requirements. Custom labels are available upon request. Please call 1-800-280-9517 or visit www.pesd.com*

Figure 1

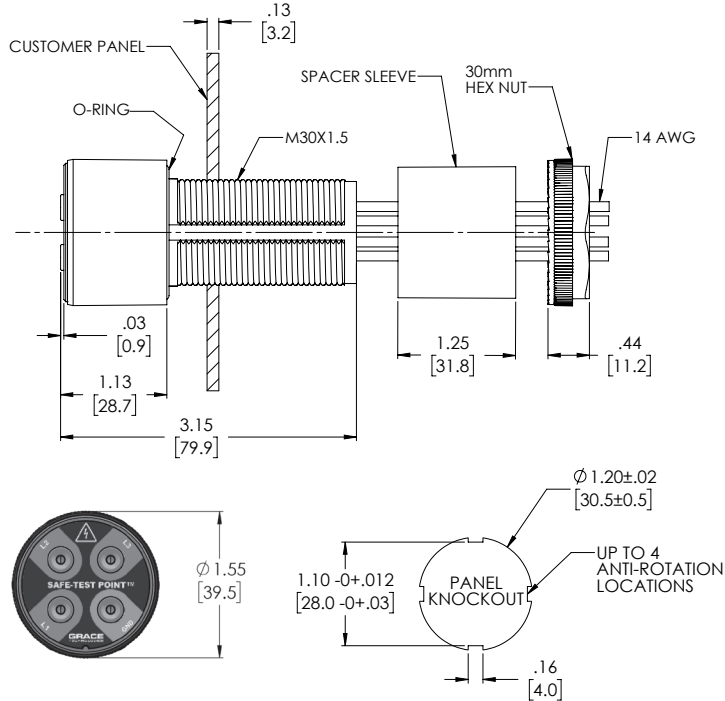
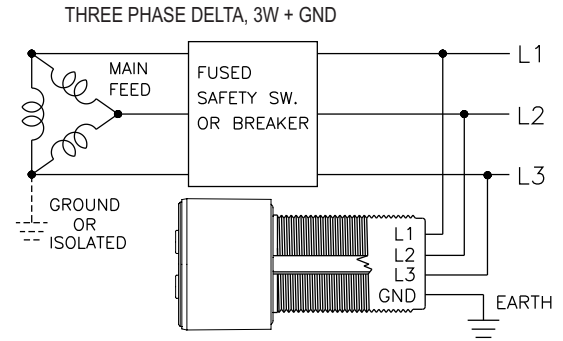

Figure 2



Note: Use abrasion and cut resistant wire sleeves to route the device leads to protect against mechanical damage resulting from sharp edges and door hinges.

Note: (4) Test point jacks accept .080" DIA. probe points.

Figure 3

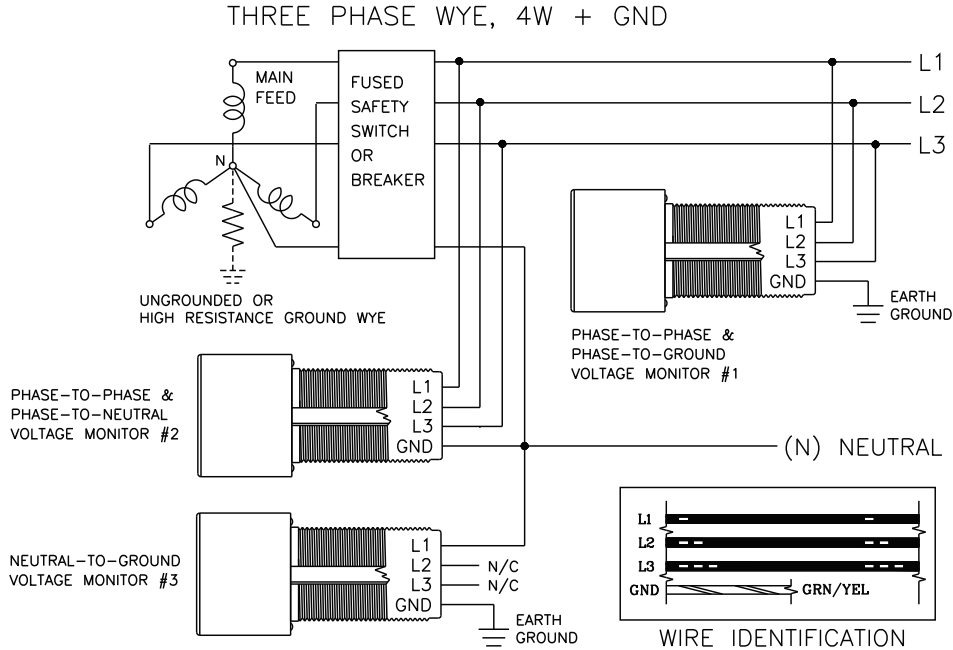

Figure 4

